



Monark 23:1 Stubby Pump

- **Delivers up to 0.5 gpm (1.9 lpm) at up to 2760 psi (19.0 MPa, 190.3 bar) fluid pressure**
- **UHMWPE packings for extended pump life in abrasive fluids**
- **Stubby design for convenient wall mounting**
- **Severe Duty design resists wear and corrosion**

**A high pressure,
durable pump
for the toughest
applications**

Graco's Monark 23:1 airless spray pump is designed to handle the rugged environment of protective coatings applications, as well as the demanding production needs of the heavy equipment manufacturer. Graco's superior pump technology delivers high performance and trouble-free reliability. Choose our standard carbon steel or complete stainless steel construction for corrosive coatings.

Typical Fluids Handled

- Solventborne fluids
- High solids
- Plural component fluids
- Primers
- Stains
- Sealants & low viscosity adhesives
- Laquers and varnishes

Typical Applications

- Wood furniture, cabinets and other wood products
- Commercial, military and civilian aircraft
- Farm and construction equipment
- Fabricated metal products

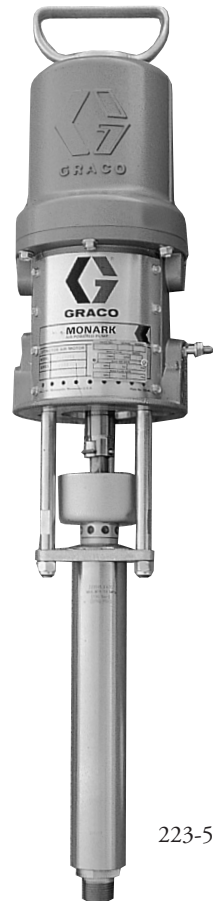

223-596

Technical Specifications

Maximum continuous flow	0.5 gpm (1.9 lpm)
Volume/Cycle	1.1 oz.
Air motor diameter	3 in. (7.6 cm)
Maximum air inlet pressure	
223-596	120 psi (0.8 MPa, 8 bar)
237-958	150 psi (1.0 MPa, 10 bar)
Maximum fluid pressure	
223-596	2760 psi (19.0 MPa, 190 bar)
237-958	3450 psi (24 MPa, 238 bar)
Air inlet size	3/8 npt(f)
Fluid inlet size	3/4 npt(m)
Fluid outlet size	3/8 npt(f)
Weight	24 lb. (11 kg)
Instruction manual	307-619

Dimensions

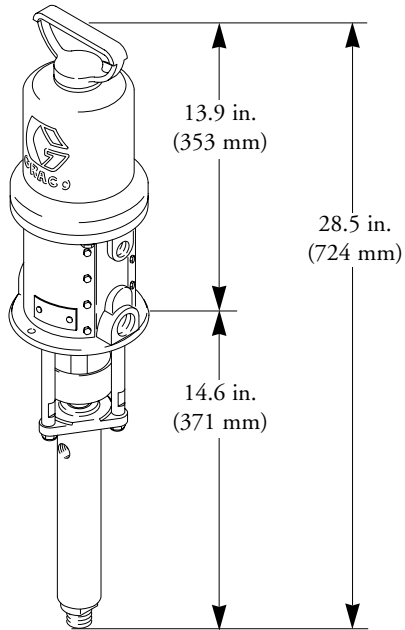

Mounting Hole Layout

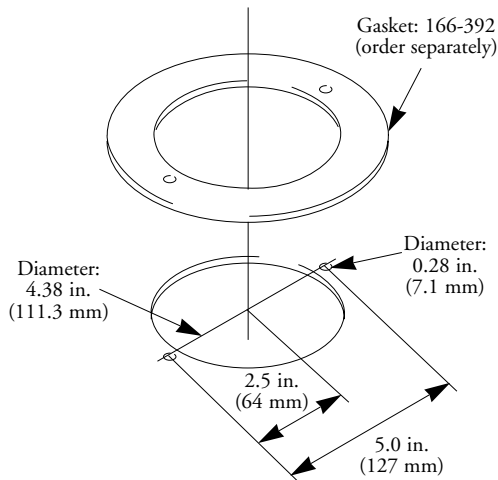

Performance Charts for Monark 23:1 Stubby Pump

Fluid Pressure

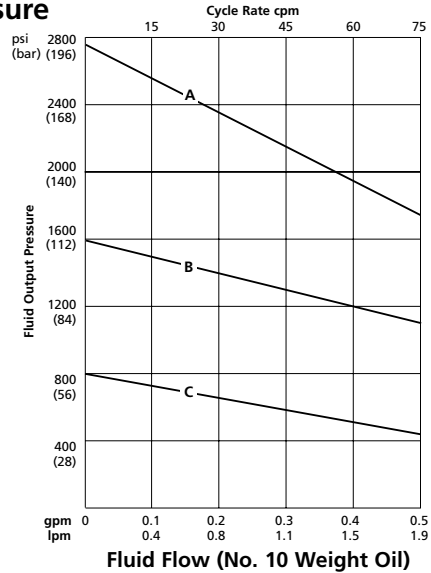

Air Consumption

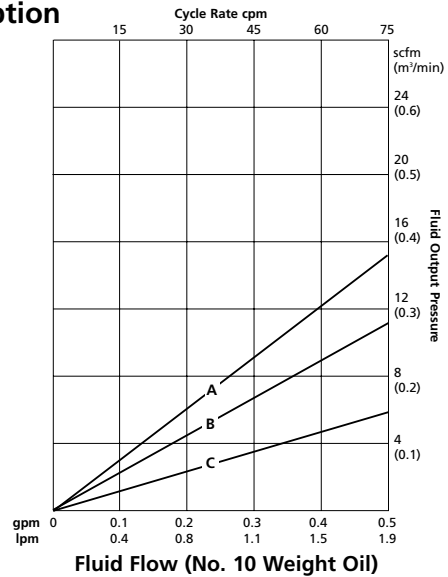

Air Pressures:

A = 120 psi (0.8 MPa, 8 bar)

B = 70 psi (0.47 MPa, 4.7 bar)

C = 40 psi (0.27 MPa, 2.7 bar)

Performance tested in No. 10 Weight motor oil (65 cp at 68° F (20° C))

Ordering Information for Monark 23:1 Stubby Pump

Order number includes motor and pump lower assembly

Order Nos.	223-596	237-958
Pump Lower		
Part No.	223-595	239-145
Construction	CS	SST
Standard Seal Repair Kits	235-636	239-328
Construction	Teflon®/Leather	Teflon/Leather
Optional Seal Repair Kits		
All Models		
236-724 Teflon		
223-674 UHMWPE/Leather		
Motor		
206-728: Repair Kit		

SERVICE PARTS INFORMATION

Pump Lower Part Nos.	223-595	239-145
Displacement Rod	223-603	223-603
Construction	SST	SST
Cylinder	178-898	178-898
Construction	SST	SST
Intake Valve (order separate part numbers)		
Intake Ball	105-445	101-750
Intake Valve Seat	223-593	223-593
Piston Valve (order separate part numbers)		
Piston Ball	105-444	102-119
Seat	223-591	223-591

Teflon® is a registered trademark of Du Pont.

Accessories

106-148 Air Line Filter

Max. working pressure 250 psi (1.8 MPa, 18 bar).
Inlet and outlet: 3/8 npt(f).

110-234 Air Regulator

Max. working pressure 300 psi (2.1 MPa, 21 bar).
Regulated pressure range: 0-250 psi (0-1.8 MPa, 18 bar).
Inlet and outlet: 3/8 npt(f).

214-847 Air Line Lubricator

Max. working pressure 250 psi (1.8 MPa, 18 bar).
Bowl capacity: 5 oz. (0.15 liter). Inlet and outlet: 3/8 npt(f).

110-150 Air FRL Kit

Max. working pressure 250 psi (1.8 MPa, 18 bar).
Includes: air filter, regulator, pressure gauge, lubricator, mounting bracket, and connection fittings. Inlet and outlet: 3/8 npt(f).

224-040 Pump Runaway Valve

Max. working pressure 120 psi (0.84 MPa, 8.4 bar).
Inlet and outlet: 3/4 npt(f).

Air Hose

Part No.	I.D. Size	Length	Thread
214-650	1/2 inch	5 ft. (1.5 m)	3/8 npt(m)
214-655	1/2 inch	25 ft. (7.6 m)	3/8 npt(m)
214-654	1/2 inch	50 ft. (15.2 m)	3/8 npt(m)
214-653	1/2 inch	100 ft. (30.4 m)	3/8 npt(m)

214-570 Carbon Steel Fluid Filter

Max. working pressure 3000 psi (21 MPa, 210 bar). Screen: 60 mesh (250 micron). Inlet: 3/8 npt(f), outlet: 1/4 npt(f).

223-160 Stainless Steel Fluid Filter

Max. working pressure 5000 psi (34.5 MPa, 345 bar). Screen: 60 mesh (250 micron). Inlet: 3/8 npt(f), outlet: 1/4 npt(m).

Stainless Steel Replacement Screens (3-pack)

Part No.	Area/sq.	Mesh	Material
238-435	18 in. (116 cm)	30	SST
238-437	18 in. (116 cm)	60	SST
238-439	18 in. (116 cm)	100	SST
238-441	18 in. (116 cm)	200	SST

207-365 Wall Bracket

Includes all screws, washers, and nuts for fastening the pump to the bracket.

208-259 Siphon Kit

For use with drums. Outlet size: 3/4 npt(f) swivel.